

Copying of this document and giving it to others
 and the use or communication of the contents thereof,
 are forbidden without express authority. All rights reserved.

Weitergabe und Vervielfältigung dieser Unterlage, sowie
 Verwertung und Mitteilung ihres Inhalts nicht gestattet,
 soweit nicht ausdrücklich zugestanden. Alle Rechte vorbehalten

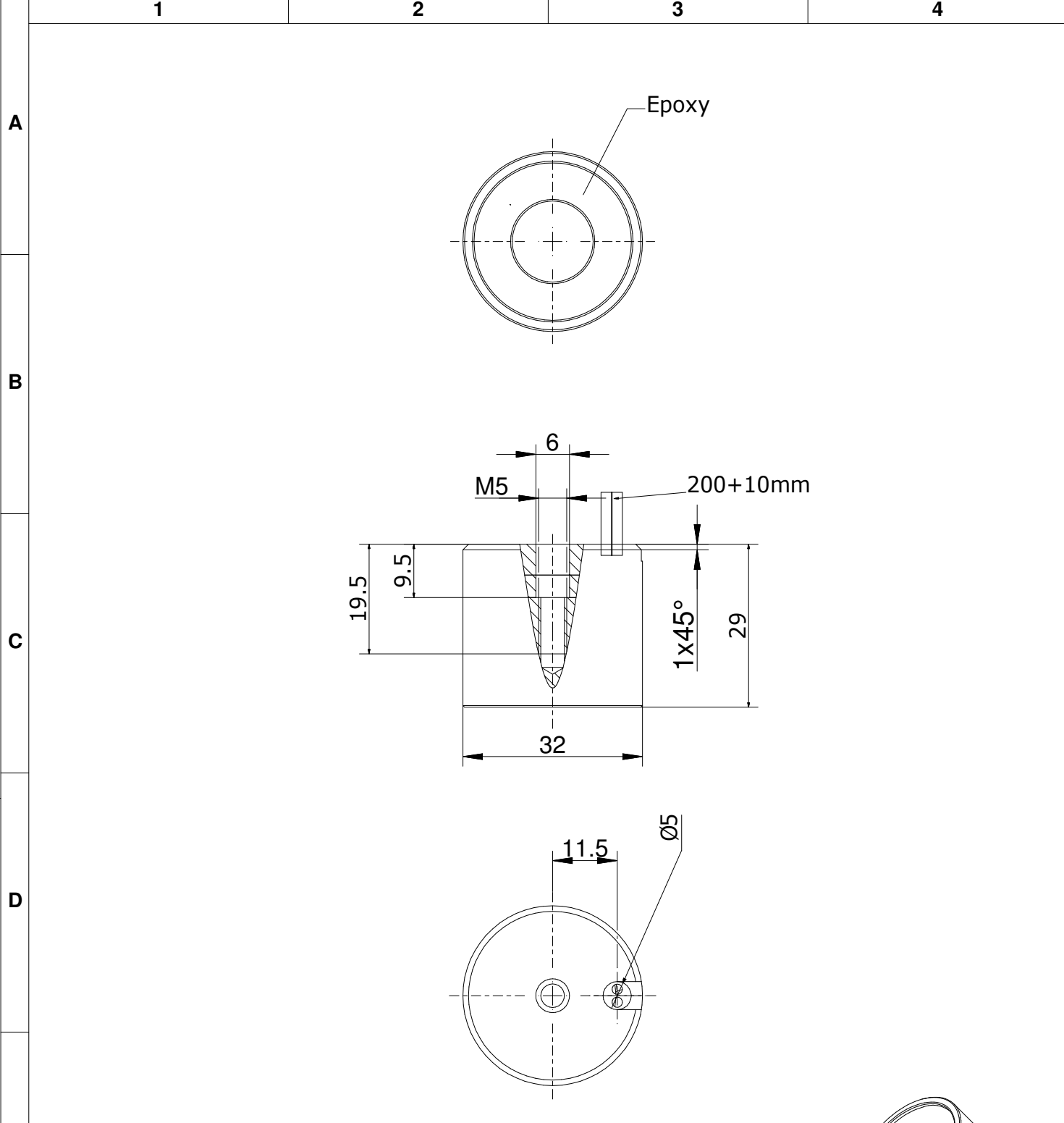

E NOTE:

1. 14,4W
2. 0mm stroke, Permanent Force 180N
3. Duty: 10%

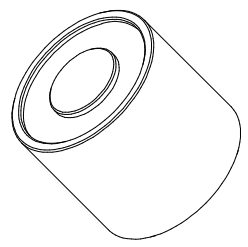

		Maße in mm Dimensions in millimeters		Zul. Abw. f. Maße ohne Toleranzang. General tolerances		Fertigungszustand finished cond.		Maßstab Scale 1:1		Menge Quantity 1	
				ISO 2768-Km				Rohstoff/Raw material -		Rohteil-Nr./Raw piece No. -	
				2008 Datum Date		Name Name		Werkzeug-Nr./Tool No. -		Benennung/Designation	
				Bearb. Drawn 21.04.08		C. Franke		PE- Magnet Ø32x29			
				Gepr. Check. 21.04.08		R. Mannel				Sachnummer/Part-No.	
								4230020 12V		4240020 24V	
A Ausg. Issue		21.04.08 Datum Date		CF Name Name		Dateiname Filename		Ursprung Source		von of 1	
								MegaCAD			