

Copying of this document and giving it to others,
 and the use or communication of the contents thereof,
 are forbidden without express authority. All rights reserved.

Weitergabe und Vervielfältigung dieser Unterlage, sowie
 Verwertung und Mitteilung ihres Inhalts nicht gestattet,
 soweit nicht ausdrücklich zugestanden. Alle Rechte vorbehalten

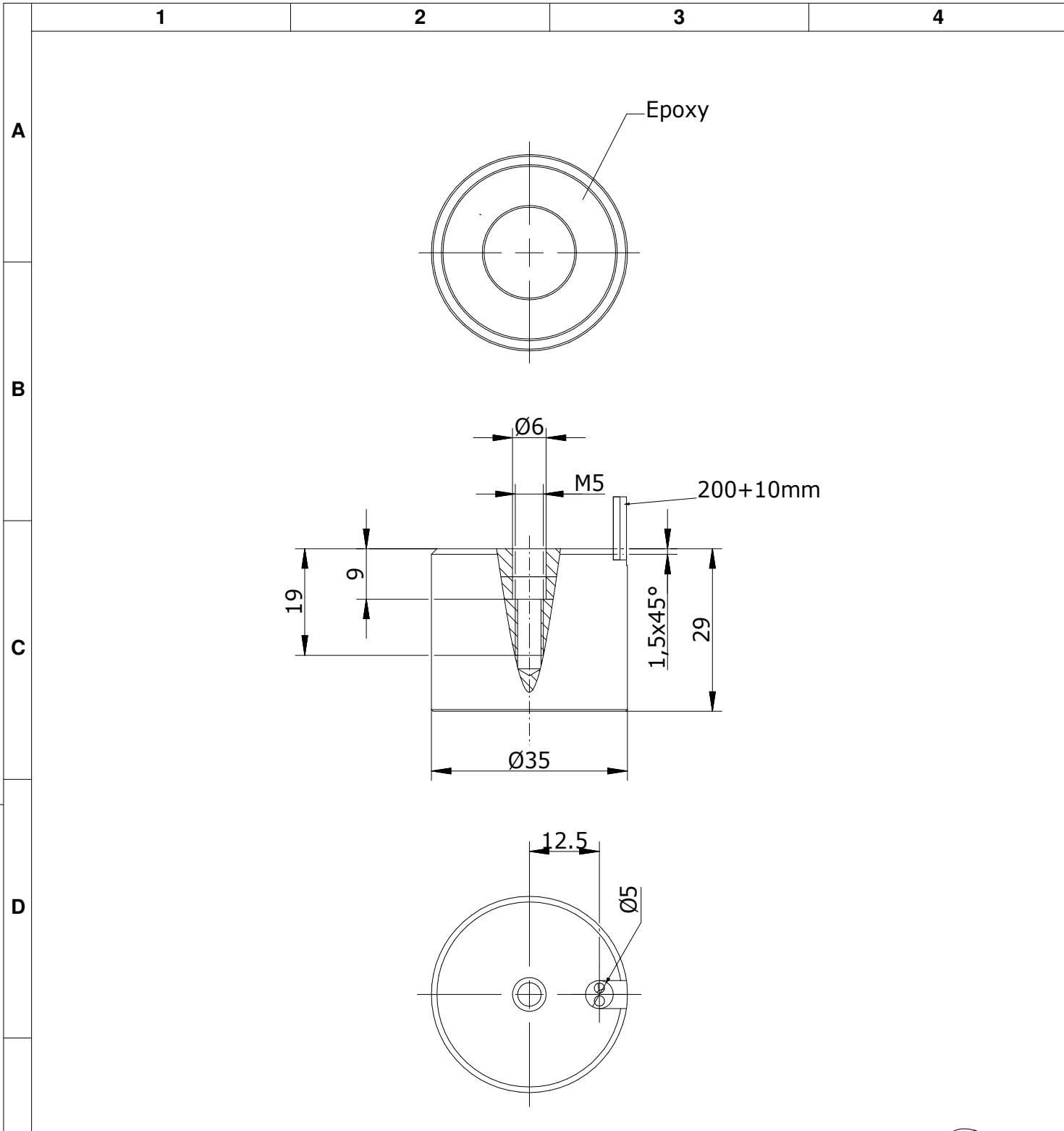

E NOTE:

1. 28W
2. 0mm stroke, Permanent Force 300N
3. Duty: 10%

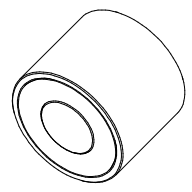

		Maße in mm Dimensions in millimeters		Zul. Abw. f. Maße ohne Toleranzang. General tolerances		Fertigzustand finished cond.		Maßstab Scale 1:1		Menge Quantity 1	
				ISO 2768-Km				Rohstoff/Raw material - Rohteil-Nr./Raw piece No. - Werkzeug-Nr./Tool No. -			
				2008	Datum Date	Name Name	Benennung/Designation				
				Bearb. Drawn	21.04.08	C. Franke	PE- Magnet Ø35x29				
				Gepr. Check	21.04.08	R. Mannel					
				Norm Appr.			Sachnummer/Part-No.				Blatt Sheet 1
							4230023 12V		4240023 24V		von of 1
A	Ausg. Issue	21.04.08	Datum Date	CF	Name Name	Dateiname Filename	Ursprung Source		MegaCAD		