

The reproduction, distribution and utilization of this document as well as the communication of its contents to others without express authorization is prohibited. Offenders will be held liable for the payment of damages. All rights reserved in the event of the grant of a patent, utility model or design.

Weitergabe sowie Vervielfältigung dieses Dokumentes, Verwertung und Mitteilung seines Inhalts sind verboten, soweit nicht ausdrücklich gestattet. Zuwiderhandlungen verpflichten zu Schadenersatz. Alle Rechte für den Fall der Patent-, Gebrauchsmuster- oder Geschmacksmusterertragung vorbehalten.

(c) MegaCAD

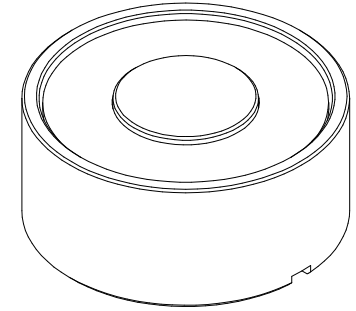
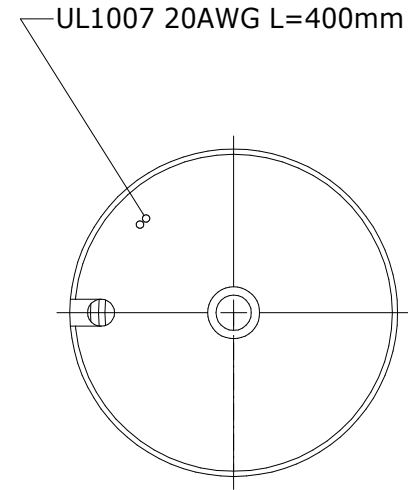
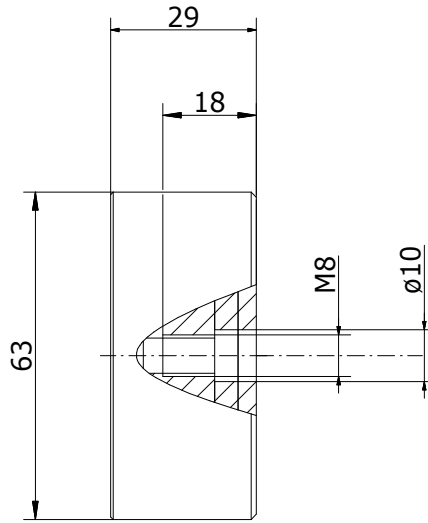
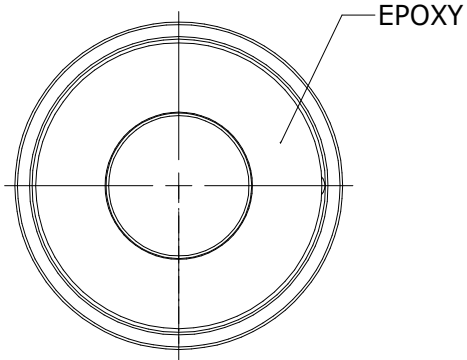

NOTE:

1. 33W
2. 0mm stroke, Force is 960N
3. Duty: 10%

		Maße in mm Dimensions in millimeters 	Zul. Abw. f. Maße ohne Toleranzang. General tolerances ISO 2768-Km	Fertigzustand finished cond.	Maßstab Scale 1:1	Menge Quantity 1
		Benennung/Designation PE-Magnet Ø63x29mm			Rohstoff/Raw material - Rohteil-Nr./Raw piece No. - Werkzeug-Nr./Tool No. -	
		2010 Datum Date 08.01.10	Name Name C. Franke	Sachnummer/Part-No. 4230035 12V 4240035 24V		
		Bearb. Drawn 08.01.10	Gepr. Check. 08.01.10	Blatt Sheet 1 von of 1		
		Norm. Appr.				
Ausg. Issue	Änderung Modification	Datum Date	Name Name	Dateiname Filename	Ursprung Source	