

Copying of this document and giving it to others, and the use or communication of the contents thereof, are forbidden without express authority. All rights reserved.

Weitergabe und Vervielfältigung dieser Unterlage, sowie Verwertung und Mitteilung ihres Inhalts nicht gestattet, soweit nicht ausdrücklich zugestanden. Alle Rechte vorbehalten

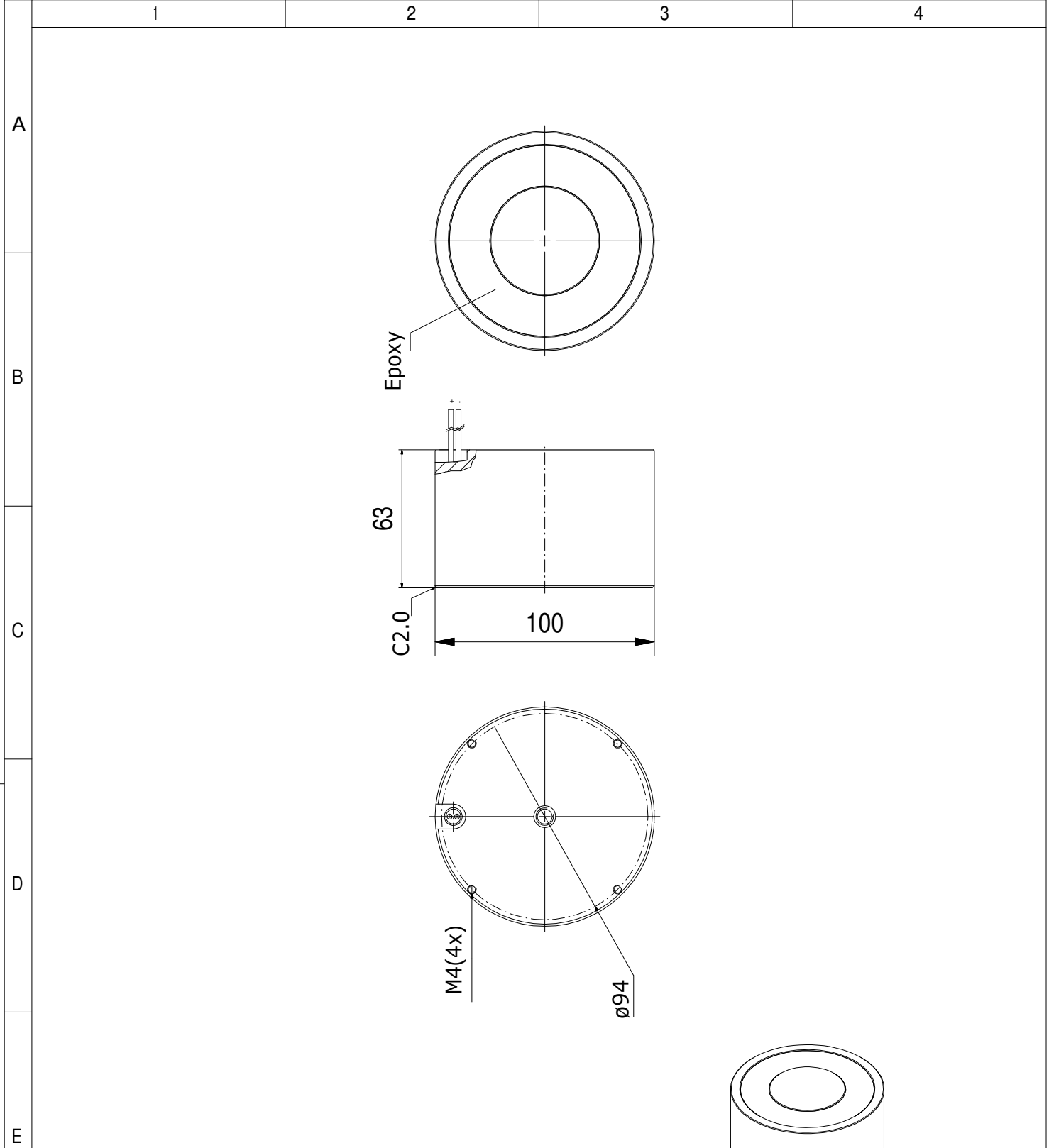

Power [W]	58
Force pm [N]	2800
Anchor Thickn. [mm]	8
Duty [%]	10

		Maße in mm Dimensions in millimeters		Zul. Abw. f. Maße ohne Toleranzang. General tolerances		Fertigzustand finished cond.		Maßstab Scale 2:1		Menge Quantity 1	
				ISO 2768-Km				Rohstoff/Raw material -		Rohteil-Nr./Raw piece No. -	
				2011		Datum Date 30.05.11		Name Name C. Franke		Benennung/Designation	
						Bearb. Drawn 30.05.11		Name Name R. Mannel		PE- Magnet ø100x63	
						Gepr. Check 30.05.11				Sachnummer/Part-No.	
						Norm Appr.				4231045 12V	
										4241045 24V	
Ausg. Issue		Anderung Modification		Datum Date		Name Name		Dateiname Filename		Ursprung Source	
										Blatt Sheet 1 von of 1	